

TREATMENT PRODUCTS CORPORATION

Wastewater Treatment & Recovery Systems

P.O. Box 444 Thorndale Pa. 19372-9998

Phone (610) 384-6279 Fax (610) 384-6239

Email sales@treatmentproducts.com

Website www.treatmentproducts.com

Flexographic Ink Treatment

CROSS-FLOW MEMBRANE-FILTRATION

APPLICATIONS

- Flexographic Printing
- Newspapers
- Box Plants

BENEFITS

- **Minimal operator attention required.**
- **Treatment Chemicals and Filter Aids are not required.**
- **Produces less waste for disposal.**
- **Water Reuse:** Since chemicals are not required for treatment the filtrate is not contaminated by treatment chemicals. The filtrate usually only contains insignificant traces of color (pale rose color) it may be practical to capture and reuse the filtrate as pre-wash water. This ability to reuse the filtrate minimizes the need to sewer or dispose of the spent wash water, thereby minimizing or eliminating expensive laboratory testing.
- **Ink Recovery:** The concentrated ink stream contains the majority of the ink and has considerable value. If different color wash waters are segregated the concentrated ink can often be returned directly to the press. If segregation by ink color is not practiced the concentrated ink blend can be blended to form a black ink. If the ink is reused disposal is not required and all disposal costs are eliminated.
- **Effluent Quality:** Produces a lower effluent metals levels than conventional systems. Most metals typically reduced below 0.5 PPM.
- **Reduction of Sampling Cost:** Sampling cost and laboratory charges can be substantially reduced or eliminated via recycling.
- Easy to Install
- Simple Operation
- Rugged Construction
- Automatic Controls
- Positive physical barrier
- Low Operating Pressure
- Consistent Filtrate Quality
- Easy to Clean

BACKGROUND

Flexographic Printing using Water Based Inks is continuing to gain popularity in the printing industry due the reduction in solvent use, the ease of cleanup, and the high print quality. These inks have significantly less environmental risk than conventional inks. However many of these inks still contain small quantities of metals for pigmentation such as copper and zinc. The press wash-up water containing the residual ink must frequently be treated prior to disposal to remove the ink solids and residual metals.

The conventional treatment method is to chemically treat the wash water to precipitate the ink solids as a sludge. Typically Alum is used as a coagulant and polymer may be used to aid in the agglomeration and settling process. The ink solids containing the metals settle to the bottom of the treatment tank, the supernatant or liquid layer typically rose colored is decanted to sewer and the sludge is collected, and dried prior to off-site disposal.

Although this process can be quite effective, it is usually labor intensive. The constantly varying composition of the wash water requires considerable operator attention to optimize the chemical; treatment dosages for proper precipitation, in many cases the process is manual with little or no automation... The process produces large sludge volumes as both the ink solids and the alum hydroxide formed during chemical treatment form the sludge.

Cross-flow Membrane Filtration utilizing either Ultra-filtration or Micro-Filtration Membranes provides an excellent alternative to the conventional treatment process. Membrane filtration does not require the use of treatment chemicals, and therefore produces up to 50% less sludge for disposal. Since separation is achieved by simple filtration considerably less operator attention is required.

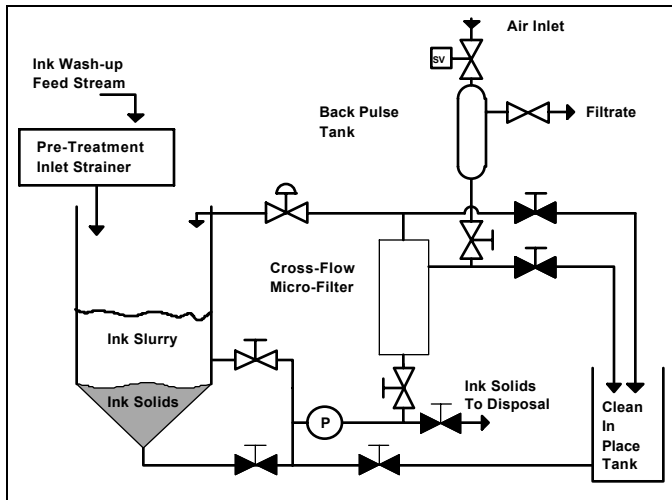

Schematic Representation of Typical Cross-Flow Micro-Filtration Flexographic Wash-up Waste Treatment System

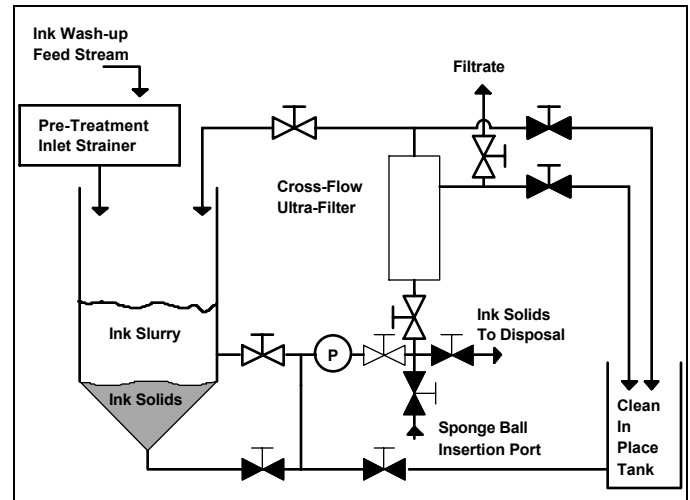

Schematic Representation of Typical Cross-Flow Ultra-Filtration Flexographic Wash-up Waste Treatment System

PROCESS OPERATION

The Cross-Flow Membrane-Filter typically resembles a shell and tube heat exchanger with porous tubular membranes. The wash water containing ink solids is recirculated at high axial velocities through the tubes and clean filtrate passes radially through the tube walls. The ink solids concentrate in the recirculation tank and must be periodically removed for dewatering or disposal. The porous tubes provide a positive physical barrier to ink solids. The ink solids are removed without the aid or use of agglomerating agents or filter aids.

MICRO-FILTRATION

The recirculation flow helps to continuously clean the tube walls. Eventually solids foul the membrane and reduce the filtrate rate. To maintain high filtrate rates a backpulse system is often utilized with cross-flow micro filtration systems (not available for Ultra-Filters). The backpulse system uses pressurized air to periodically force filtrate momentarily backward through the tube walls. The solids are pulsed off the interior tube wall surface and are swept from the filter by the recirculation stream. Eventually the membranes are fouled to the point where chemical cleaning is required. For flexographic ink removal applications the micro-filtration membranes are typically cleaned by pumping flexographic ink cleaning solutions through the tubular membranes. Typical cleaning frequency based on 24 hour a day operation is once or twice week and requires approximately 20 - 30 minutes per cleaning.

ULTRA-FILTRATION

Eventually the membranes are fouled to the point where chemical cleaning is required. For flexographic ink removal applications the ultra-filtration membranes are typically cleaned by pumping proprietary detergents or flexographic ink cleaning solutions through the tubular membranes while using sponge balls to mechanically scrub the tube walls. Typical cleaning frequency based on 24 hour a day operation is once or twice week and requires approximately 20 - 30 minutes per cleaning.

KEYS TO SUCCESSFULL PERFORMANCE

The main key to success with membrane filtration treatment system for flexographic ink treatment is to keep the ink from spoiling or turning septic prior to treatment. Oxidizing agents must be added liberally daily to all ink sumps and collection points as well as to the recirculation tank. For our micro-filtration membranes Hydrogen Peroxide must be used and for our ultra-filtration membranes Hydrogen Peroxide or Sodium Hypochlorite (household bleach) may be used.

It is also important to provide a strainer prior to the recirculation tank to remove ink lumps and other debris that may clog the membrane tubes.

The final important step is to flush and clean the membranes prior to idle periods in excess of 8 hours. This prevents the ink solids from settling out and plugging the membrane tubes.

For further information contact.

Represented By:



Wastewater Treatment & Recovery Systems
 P.O. Box 444 Thorndale Pa. 19372-9998
 Phone (610) 384-6279 Fax (610) 384-6239
 Email sales@treatmentproducts.com
 Website www.treatmentproducts.com